

Accessories

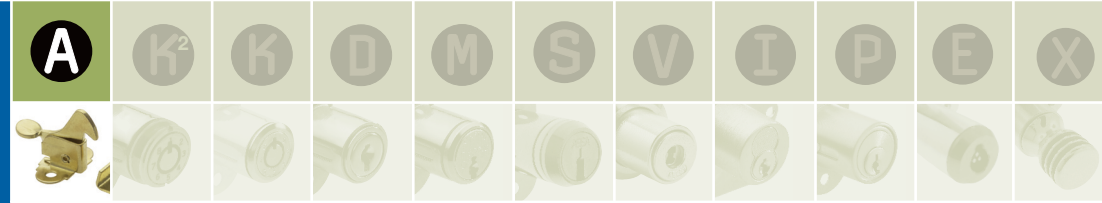

Face Sleeves, Collars and Spacers	$\frac{A}{1}$			
Spacers and Washers	$\frac{A}{2}$			
Washers and Strikes	$\frac{A}{3}$			
Strikes Plates	$\frac{A}{4}$			
Mounting Plates	$\frac{A}{5}$			
Mounting Plates and Gang Lock Hardware	$\frac{A}{6}$			
Ratchet Bars and Miscellaneous	$\frac{A}{7}$ $\frac{A}{8}$			
Miscellaneous and Packages	$\frac{A}{9}$			
I.C. Cam Lock Glass Kit, Switch Kit and Cams	$\frac{A}{10}$			



FACE SLEEVE

Item Number

A	U	CL	FSL	XXX	108	Plating Finish*
						PN
						PB
						BL
						ST
						CF

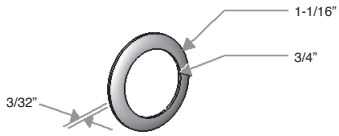

A decorative mounting for use with **D, K, M, S, V** and **E** Cam Locks. The Face Sleeve can also be used to position the Cam.

FACE SLEEVE

Item Number

A	U	CL	FSL	XXX	124	Plating Finish*
						PN
						PB
						BL
						ST
						CF

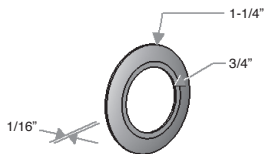

A decorative mounting for use with **D, K, M, S, V** and **E** Cam Locks. Made in the U.S.A. The Face Sleeve can also be used to position the Cam.

TRIM RING

Item Number

A	U	DL	TRM	RNG	110	Plating Finish*
						PN
						SB
						ST
						CF

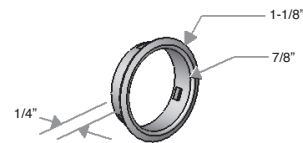

For use with **D, K, K2, M, S** and **E** Drawer/Door and Plunger Locks.

COLLAR/SPACER

Item Number	Length	Plating Finish*
A U CL COL SPA 013	1/8"	PC
025	1/4"	
038	3/8"	
053	17/32"	

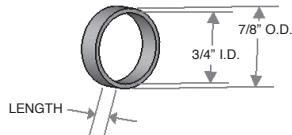

For use with **D, K, M, S, V** and **E** Cam Locks.

COLLAR/SPACER

Item Number

A	K2	CL	COL	BVL	XX	Plating Finish*
						PN
						PB
						CF

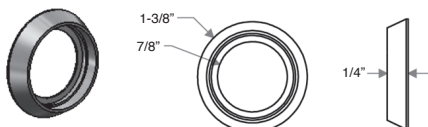

For use with **K2** and **K3** Cam Locks.

COLLAR/SPACER

Item Number

A	K2	CL	COL	019	XX	Plating Finish*
						PN
						PB
						CF

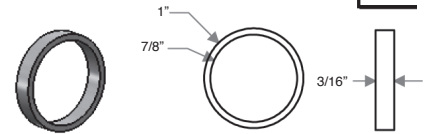

For use with **K2** Cam Locks.

COUNTERBORE DRESS RING/COLLAR

Item Number

A	K2	CL	COL	XXX	XX	Plating Finish*
						PN
						PB
						CF

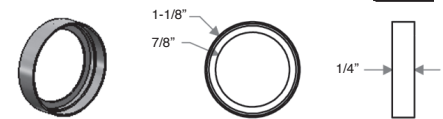

To flush mount **K2** and **K3** Cam Locks.

FLUSH MOUNT COLLAR OR SPACER TO REPLACE I.C. DL LOCKS

Item Number

A	K2	DL	COL	ADJ	FM	Plating Finish*
						PN
						BL
						CF

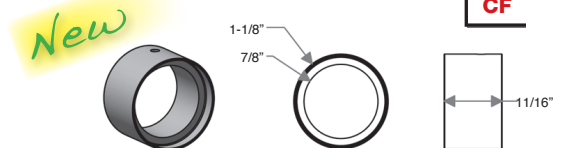

To flush mount **K2** Drawer or replace **I.C.** Locks DL locks.

COLLAR/SPACER

Item Number	Length	Plating Finish*
A I CL COL SPA 009	3/32"	AL
016	5/32"	
019	3/16"	
025	1/4"	
050	1/2"	

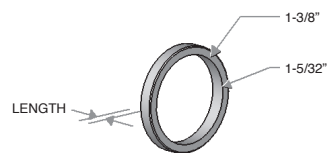

For use with **I** Cam Locks.

SPACER

Item Number

A	P	DL	SPA	PLA	010	Plating Finish*
						WH

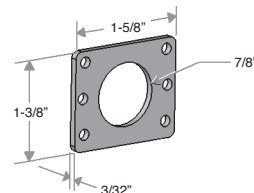

For use with **P** Drawer/Door Locks.

*Plating Finish: **PN** Polished Nickel; **PB** Polished Brass; **SB** Satin Brass; **BL** Matte Black; **ST** Statuary Bronze; **BC** Brushed Chrome; **AL** Aluminum; **WH** White; **CF** Custom Finish

Spacers/Washers

I.C. CORE RIM LOCK SPACER

Item Number					Thickness	Material*
A	I	DL	SPA	RIM	XXX 1/8"	PL
					025 1/4"	

New

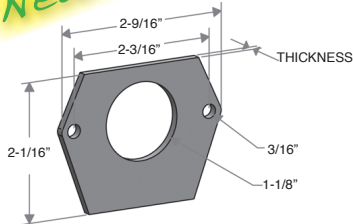

For use with **DLI20, 32** and **33** series **Rim Door/Door Locks**.

SPACER

Item Number						Color*
A	I	25	SPA	PLA	013	WH

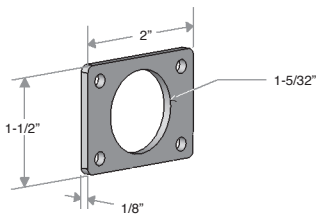

For use with **DLI25 Door/Door Locks**.

SPACER

Item Number						Plating Finish*
A	U	40	SPA	XXX	200	PN CF

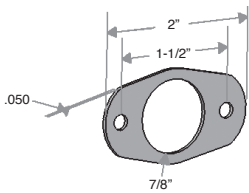

Made in the U.S.A. For use with **D, K, K2, M, S, V** and **E40** Plunger Locks.

SPACER

Item Number						Plating Finish*
A	U	DL	SPA	XXX	XXX	PN ST CF

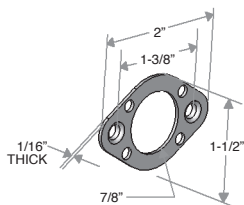

Made in the U.S.A. For use with **D, K, K2, M, S, V** and **E** Drawer/Door and Gang Locks.

PLASTIC WASHER

Item Number						
A	U	CL	WSH	PLA	099	CL

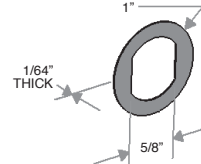

Made in the U.S.A. For use with **D, K, K3, M, S, V, P** and **E** Cam Locks.

ADHESIVE PLASTIC WASHER

Item Number						
A	U	CL	WSH	ADH	099	CL

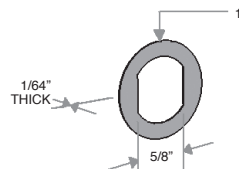

Made in the U.S.A. For use with **D, K, K3, M, S, V, P** and **E** Cam Locks.

FLAT METAL WASHER

Item Number					Plating Finish*	
A	U	CL	WSH	FLT	103	PN PB ST CF

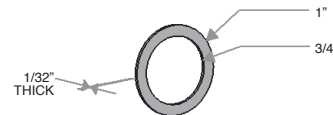

For use with **D, K, M, S, V, P** and **E** Cam Locks.

4 PRONG ANTI-ROTATION WASHER

Item Number						Plating Finish*
A	U	CL	WSH	ANR	4PR	ZN CF

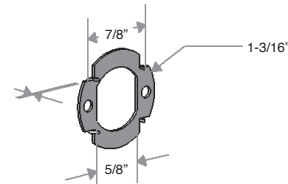

Made in the U.S.A. For use with **D, K, K3, M, S, V, P** and **E** Cam Locks.

ANTI-ROTATION THREE TAB WASHER

Item Number						Plating Finish*
A	I	CL	WSH	BRL	3FG	ZN

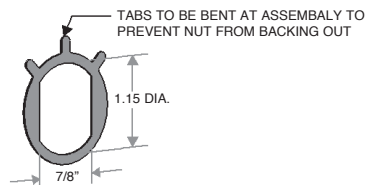

Made in the U.S.A. For use with **I** Cam Locks.

*Plating Finish/Material: **PN** Polished Nickel; **PB** Polished Brass; **BL** Matte Black; **ST** Statuary Bronze; **ZN** Zinc; **WH** White; **CF** Custom Finish; **PL** Pastic

Data Sheet

Washer/Strikes

ANTI-ROTATION THREE TAB WASHER

Item Number

A	U	CL	WSH	BRL	3FG	ZN
----------	----------	-----------	------------	------------	------------	-----------

Plating Finish*

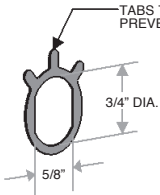

Made in the U.S.A. For use with **D, K, K3, M, S, V, P** and **E** Cam Locks.

ANTI-ROTATION THREE TAB WASHER

Item Number

A	K2	CL	WSH	BRL	3F	BN
----------	-----------	-----------	------------	------------	-----------	-----------

Plating Finish*

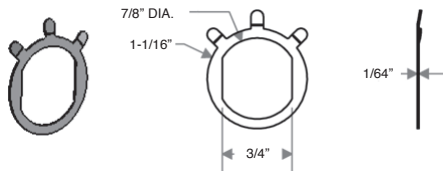

For use with **K2** Cam Locks.

PLASTIC WASHER (FOR K2 CAM LOCKS ONLY)

Item Number

A	K2	CL	WSH	XXX	XXX	CL
----------	-----------	-----------	------------	------------	------------	-----------

Plating Finish*

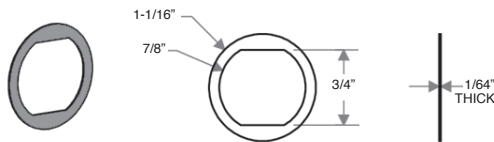

Made in the U.S.A. For use with **K2** Cam Locks.

ANTI-ROTATION THREE TAB WASHER

Item Number

A	U	CL	WSH	SPI	3FG	ZN
----------	----------	-----------	------------	------------	------------	-----------

Plating Finish*

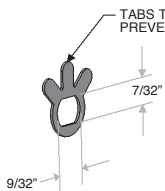

Made in the U.S.A. For use with **D, K, K3, M, S** and **V** Cam Locks.

11/16" SLOTTED STRIKE PLATE

Item Number

STR	200	PN
		CF

Plating Finish*

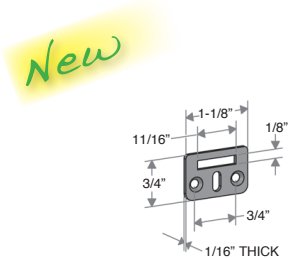

7/8" SLOTTED STRIKE PLATE

Item Number

STR	201	PN
		CF

Plating Finish*

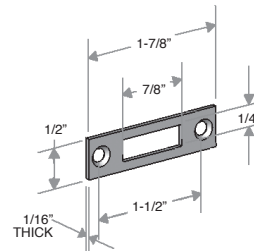

1-1/8" SLOTTED STRIKE PLATE

Item Number

STR	202	PN
		SB
		CF

Plating Finish*

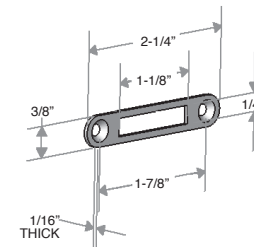

Made in the U.S.A.

1-1/4" SLOTTED STRIKE PLATE

Item Number

STR	203	PN
		CF

Plating Finish*

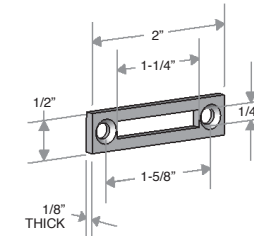

1" SLOTTED STRIKE PLATE

Item Number

STR	204	PN
		PB
		CF

Plating Finish*

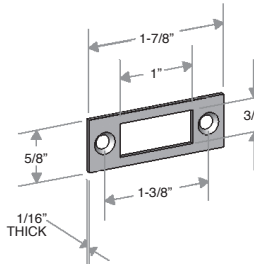

1-1/4" SOLID STRIKE PLATE

Item Number

STR	211	PN
		CF

Plating Finish*

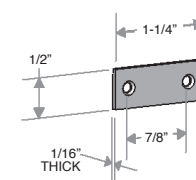

Made in the U.S.A.

*Plating Finish: **PN** Polished Nickel; **PB** Polished Brass; **SB** Satin Brass; **CF** Custom Finish

1-7/8" SOLID STRIKE PLATE

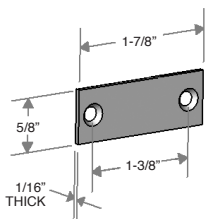

Item Number		Plating Finish*
STR	212	PN PB CF

1/2" ADJUSTABLE "L" STRIKE

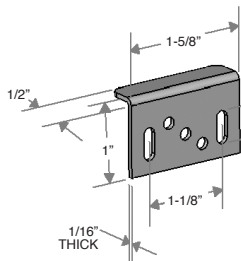

Item Number		Plating Finish*
STR	221	PN CF

1" SPRING BOLT SLOTTED STRIKE PLATE

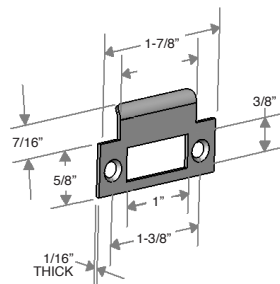

Item Number		Plating Finish*
STR	321	PN PB CF

1-7/8" SPRING BOLT SOLID STRIKE PLATE

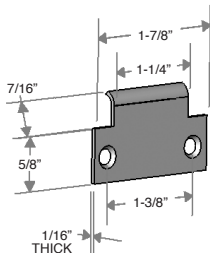

Item Number		Plating Finish*
STR	331	PN PB CF

3/16" "L" STRIKE

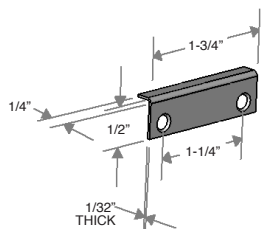

Item Number		Plating Finish*
STR	231	PN CF

Made in the U.S.A.

3/8" "L" STRIKE

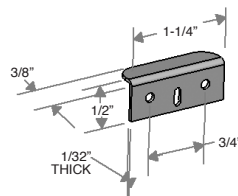

Item Number		Plating Finish*
STR	232	PN CF

1/2" "L" STRIKE

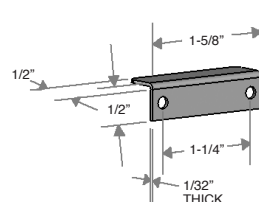

Item Number		Plating Finish*
STR	233	PN CF

13/16" "L" STRIKE

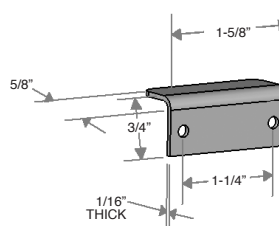

Item Number		Plating Finish*
STR	234	PN CF

Made in the U.S.A.

STRIKE PLATE

Item Number						Plating Finish*
A	U	40	STR	XTX	XXX	BN

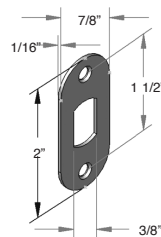

Made in the U.S.A.

For use with D, K, M, S, V and E40 Plunger Locks.

ROUND PLUNGER CUP STRIKE

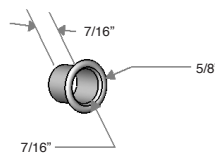

Item Number		Plating Finish*
STR	261	SN SB CF

For use with D, K, M, V and P Round Style Plungers.

*Plating Finish: **PN** Polished Nickel; **SN** Satin Nickel; **BN** Barrel Nickel; **PB** Polished Brass; **SB** Satin Brass; **BL** Matte Black; **ST** Statuary Bronze; **ZN** Zinc; **CF** Custom Finish

Data Sheet

ANTI-ROTATION MOUNTING PLATE (FOR K2 CAM LOCKS ONLY)

Item Number						Plating Finish*
A	K2	CL	PLT	ANR	X2	BN

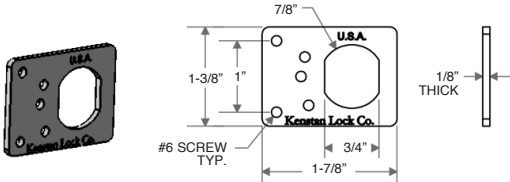

Made in the U.S.A.

For use with **K2** Cam Locks only.

ANTI-ROTATION MOUNTING PLATE

Item Number						Plating Finish*
A	U	CL	PLT	ANR	095	BN

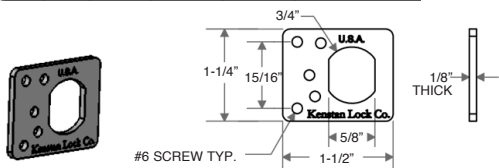

Made in the U.S.A.

For use with **D, K, K3, M, S, V, E** and **P** Cam Locks.

ANTI-ROTATION MOUNTING PLATE

Item Number						Plating Finish*
A	I	CL	PLT	ANR	XXX	ZN CF

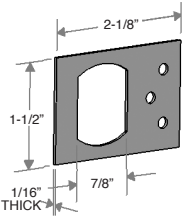

For use with **CLI** Cam Locks.

ANTI-ROTATION MOUNTING PLATE/ 3 FINGER WASHER

Item Number						Plating Finish*
A	U	CL	PLT	ANR	XXX	BN

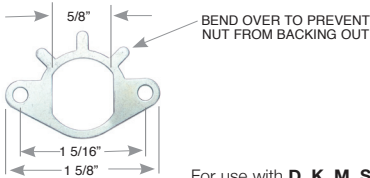

For use with **D, K, M, S, V, P** and **E** Cam Lock.

ANTI-ROTATION "J" BRACKET

Item Number						Plating Finish*
A	U	CL	JBK	ANR	026	PN PB BL ST CF

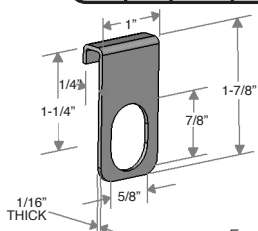

Made in the U.S.A.

For use with **D, K, M, S, V, P** and **E** Cam Locks.
Hole must be drilled 1-1/4" from edge of glass.

ANTI-ROTATION "L" BRACKET

Item Number						Plating Finish*
A	U	CL	LBK	XXX	125	PN PB BL ST CF

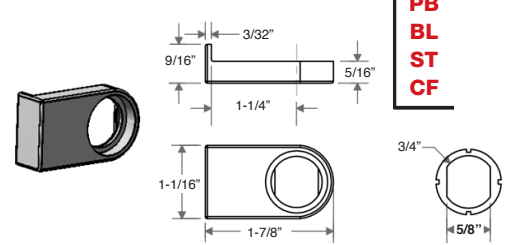

This bracket can be mounted on the top, bottom, left or right of the glass edge. For use with **D, K, M, S, V, P** and **E** Cam Locks.

ANTI-ROTATION "L" BRACKET (FOR K2 CAM LOCKS ONLY)

Item Number						Plating Finish*
A	K2	CL	LBK	XXX	125	PN PB BL ST CF

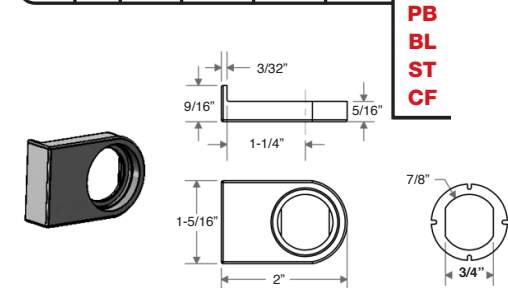

This bracket can be mounted on the top, bottom, left or right of the glass edge. For use with **K2** Cam Locks.

ANTI-ROTATION "L" BRACKET (FOR K3 CAM LOCKS ONLY)

Item Number						Plating Finish*
A	K3	CL	LBK	XXX	125	PN PB BL ST CF

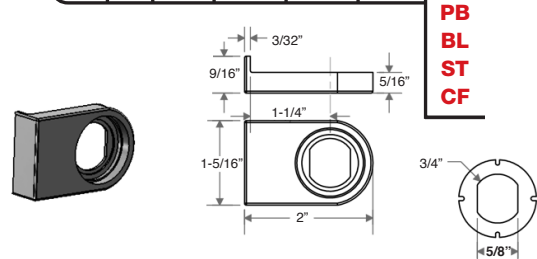

This bracket can be mounted on the top, bottom, left or right of the glass edge. For use with **K3** Cam Locks.

"J" BRACKET

Item Number						Plating Finish*
A	U	50	JBK	ANR	XXX	PN PB SN BL CF

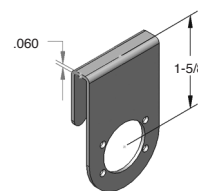

Made in the U.S.A.

For use with **D, K, K2, M** and **S50** Plunger Locks.
Hole must be drilled 1-1/2" from edge of glass.

*Plating Finish: **PN** Polished Nickel; **SN** Satin Nickel; **PB** Polished Brass; **BL** Matte Black; **PC** Polished Chrome; **SC** Satin Chrome; **RD** Red; **CF** Custom Finish

SMALL SUPPORT PLATE

Item Number

A	I	40	PLT	XXX	SML	PC	SC	PB	CF
---	---	----	-----	-----	-----	----	----	----	----

Plating Finish*

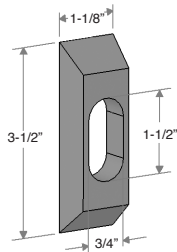

For use with **I40** Plunger Locks. Screws are included at no charge.

MOUNTING PLATE

Item Number

A	U	40	PLT	XXX	083	13/16"	PN
					137	1-5/16"	

Size

Plating Finish*

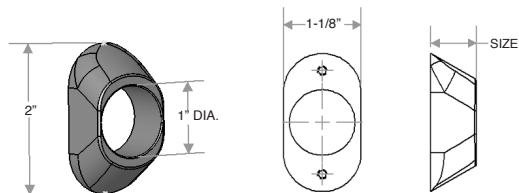

For use with **D, K, K2, M, S, V** and **E40** Plunger Locks.

MOUNTING/SPACER PLATE

Item Number

A	U	DL	PLT	MNT	SPA	PN	CF
---	---	----	-----	-----	-----	----	----

Plating Finish*

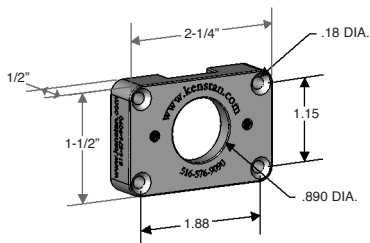

For use with **D, K, K2, M, S** and **E** Drawer/Door Locks.

DRAWER CATCH

Item Number

A	U	DL	CTH	RHT	LFT	XXX	PN
				Right	Left		

Style

Plating Finish*

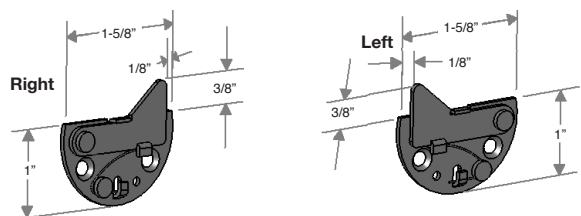

For use with self-closing Gang Lock drawers.

1/16" THICK SPLIT LOCK WASHER

Item Number

A	U	XX	WSH	LKW	026	PN
---	---	----	-----	-----	-----	----

Plating Finish*

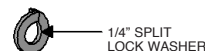

CLOSED BAR GUIDE

Item Number

A	U	GL	BGU	CLO	065	PN
---	---	----	-----	-----	-----	----

Plating Finish*

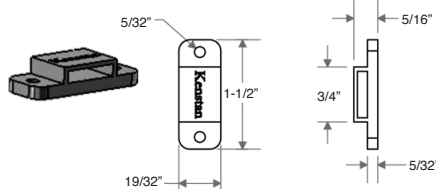

Made in the U.S.A.

OPEN BAR GUIDE

Item Number

A	U	GL	BGU	OPN	065	ZN
---	---	----	-----	-----	-----	----

Plating Finish*

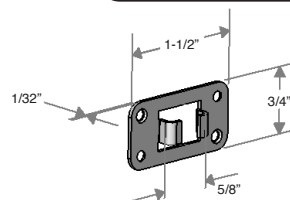

EXTENSION PIN

Item Number

A	U	XX	PIN	EXT	063	5/8"	PN
---	---	----	-----	-----	-----	------	----

Length

Plating Finish*

					075	3/4"	
					113	1-1/8"	
					188	1-7/8"	
					CL	Custom	

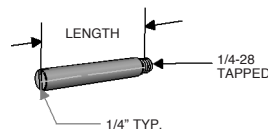

Made in the U.S.A.

ADJUSTABLE STOP

Item Number

A	U	GL	STP	ADJ	065	PN
---	---	----	-----	-----	-----	----

Plating Finish*

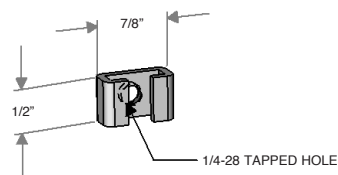

Made in the U.S.A.

For use with **D, K, M, S, V** and **I** Gang Locks.

*Plating Finish: **PN** Polished Nickel; **BL** Matte Black; **ZN** Zinc

Data Sheet

Ratchet Bars/Miscellaneous

FRONT MOUNT GANG LOCK BAR

Item Number					Length	Plating Finish*
A	U	GL	BAR	FMT	240 24"	BL
					360 36"	
					480 48"	
				CL Custom		

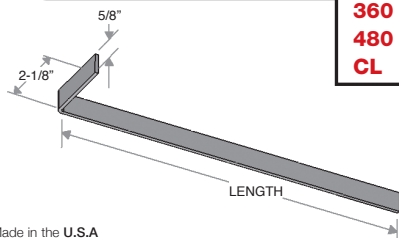

Made in the U.S.A

2 BAR ASSEMBLY

Item Number					Length	Plating Finish*
A	U	CL	BAR	2PC	CL Custom	GR

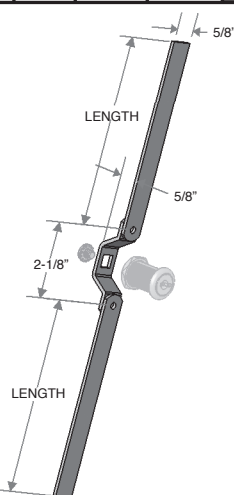

Made in the U.S.A

For use with self-closing Gang Lock drawers.

STANDARD BAR FOR RATCHET LOCK

Item Number					Plating Finish*	
A	U	60	BAR	XB1	STD	PN
						CF

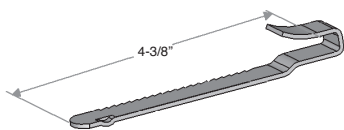

For use with **D, K, K2** and **M** Ratchet Locks.

ADJUSTABLE BAR FOR RATCHET LOCK

Item Number					Plating Finish*	
A	U	60	BAR	XB2	ADJ	PN
						CF

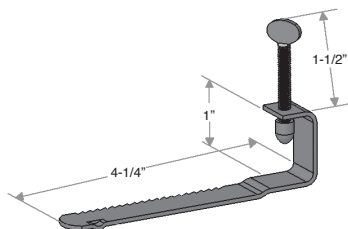

For use with **D, K, K2** and **M** Ratchet Locks.

STICK ON BAR (INNER SURFACE) FOR RATCHET LOCK

Item Number					Plating Finish*	
A	U	60	BAR	XB5	STD	PN
						CF

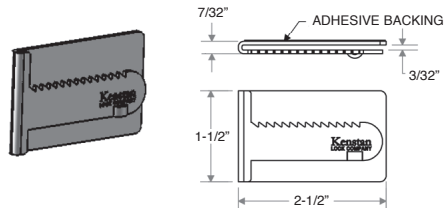

For use with **D, K, K2** and **M** Ratchet Locks.

STICK ON BAR (INNER SURFACE) FOR RATCHET LOCK

Item Number					Plating Finish*	
A	U	60	BAR	XB9	XXX	PN

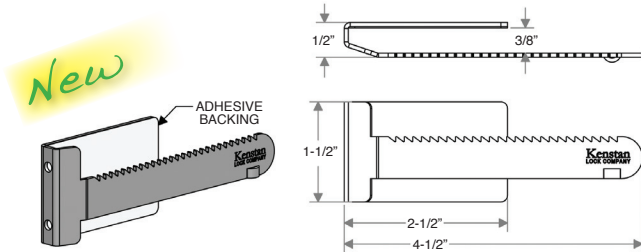

For use with **D, K, K2** and **M** Ratchet Locks.

3" CAM

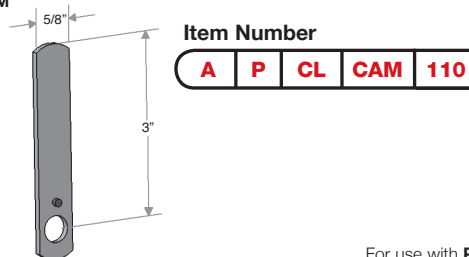

Item Number			
A	P	CL	CAM 110

For use with **P** Cam Locks.

3" I.C. CORE CAM LOCK CAM

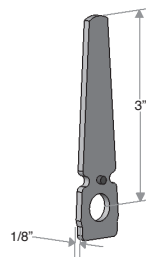

Item Number			
A	I	CL	CAM 110

For use with **I** Cam Locks.

RUBBER CAM COVER

Item Number					Plating Finish*	
A	U	CL	CVR	CAM	RBR	BL

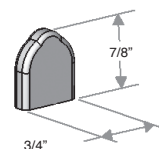

For use with Cams.

*Plating Finish: **PN** Polished Nickel; **SN** Satin Nickel; **PB** Polished Brass **BL** Matte Black; **ZN** Zinc; **CF** Custom Finish

CAM ADAPTER

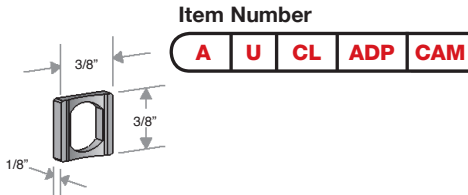

Item Number
A U CL ADP CAM

Use to mount Standard Cams on to **K, K2, M, S** and **V** Cam Locks.

6 PIN CORE SPACER

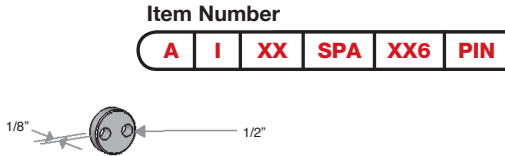

Item Number
A I XX SPA XX6 PIN

For use with **I** Locks.

RED PLASTIC ACTUATOR

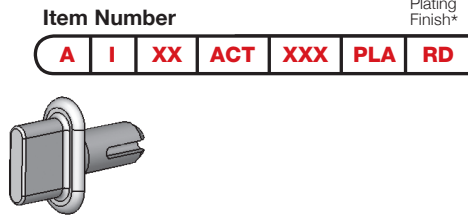

Item Number
A I XX ACT XXX PLA RD

Plating Finish*

For use with **I** Locks.

RUBBER "O" RING

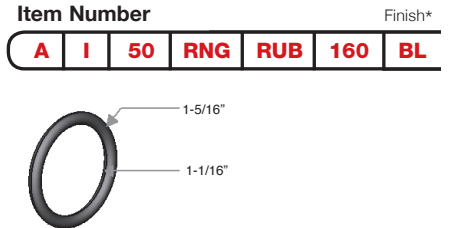

Item Number
A I 50 RNG RUB 160 BL

Finish*

For use with **150** Plunger Locks.

3/4" INTERNAL LOCK WASHER

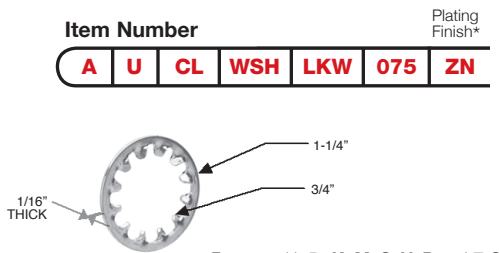

Item Number
A U CL WSH LKW 075 ZN

Plating Finish*

For use with **D, K, M, S, V, P** and **E** Cam Locks.

MOUNTING CLIP

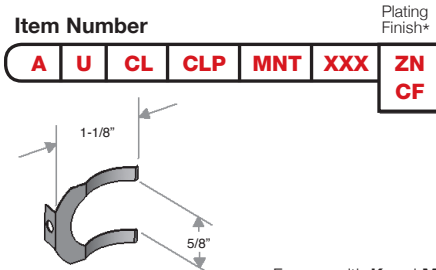

Item Number
A U CL CLP MNT XXX ZN CF

Plating Finish*

For use with **K** and **M** Cam Locks.

MOUNTING POST

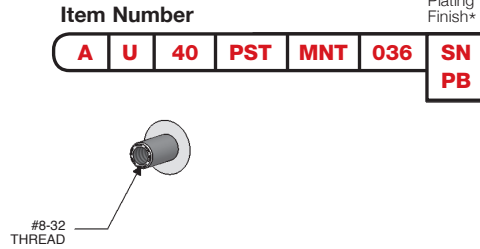

Item Number
A U 40 PST MNT 036 SN PB

Plating Finish*

Made in the U.S.A

Call Customer Service to order desired screws.

1/4" SPACER

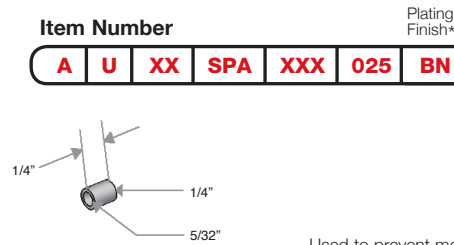

Item Number
A U XX SPA XXX 025 BN

Plating Finish*

Made in the U.S.A

Used to prevent metal track from bending when mounting locks.

K2 ACTUATOR

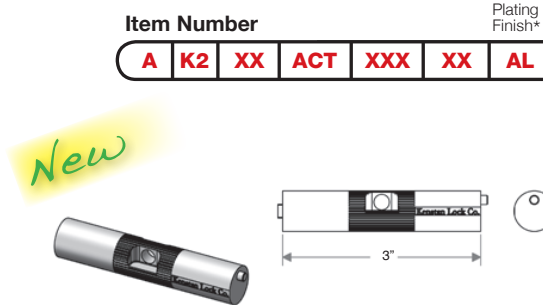

Item Number
A K2 XX ACT XXX XX AL

Plating Finish*

For use with **K2** Locks.

DISC TUMBLER REMOVABLE CORE ACTUATOR

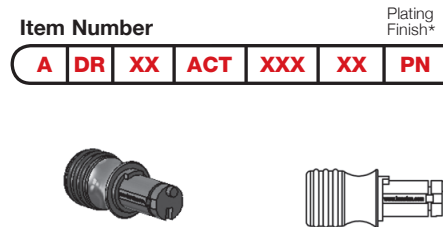

Item Number
A DR XX ACT XXX XX PN

Plating Finish*

For use with Disc Tumbler removable core locks.

PLUG REMOVAL TOOL

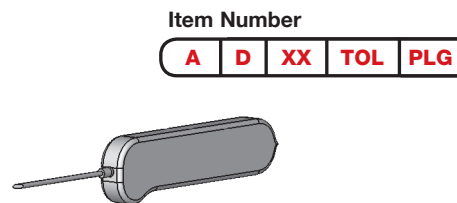

Item Number
A D XX TOL PLG

For use with some **D** Locks.

*Plating Finish: **PN** Polished Nickel; **SN** Satin Nickel; **PB** Polished Brass **BL** Matte Black; **ZN** Zinc; **RD** Red; **AL** Aluminum **CF**; Custom Finish

Data Sheet

Miscellaneous/Packages

SECURITY HEX KEY

Item Number							Plating Finish*
A	U	XX	TOL	HEX	003	BL	



Use to made PL_51 series captive.

SECURITY HEX KEY

Item Number							Plating Finish*
A	U	XX	TOL	HEX	009	BL	

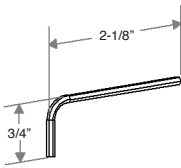

Use to remove Security Screw from Plunger Locks.

ELBOW CATCH

Item Number							Plating Finish*
A	U	XX	CTH	ELB	XXX	PB CF	



Use to secure the second door when using double doors.

DUST COVER

Item Number							Plating Finish*
A	U	CL	CVR	DST	XXX	BN CF	



For use with D, K, M, S, V, P and E Cam Locks.

FINGER PULL

Item Number							Plating Finish*
A	U	CL	PUL	FGR	XXX	PN CF	

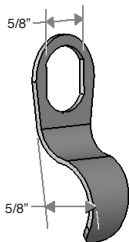

For use with D, K, M, S, V, P and E Cam Locks.

GANG LOCK PACKAGE

To determine your item number enter the **RED** option code for each section as in the example below.

A	B	C
GANG	3	C

GANG 3C A kit with three adjustable stops, three 1-1/8" pins, three lock washers, and four closed bar guides.

A Package
GANG

B Number of Drawers
2
3
4
5
6

C Pin Length
A 5/8"
B 3/4"
C 1-1/8"
D 1-7/8"

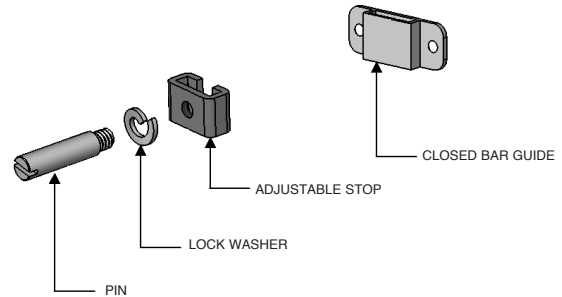

CAM LOCK GLASS INSTALLATION PACKAGE

A	B
CLLKXX	PN

CLLK XX PN A kit with two plastic and one Polished Nickel "L" bracket.

A Package
CLLKXX

B Plating Finish
PN Polished Nickel
PB Polished Brass
BL Matte Black
ST Statuary Bronze
CF Custom Finish

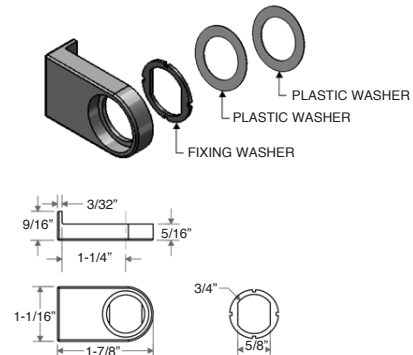

I.C. CORE CAM LOCK GLASS INSTALLATION PACKAGE



CLIKK BC A kit with one "L" bracket and two plastic washers.

A Package
CLIKK

B Plating Finish
PC Polished Chrome
BC Brush Chrome
PB Polished Brass
BL Matte Black
CF Custom Finish

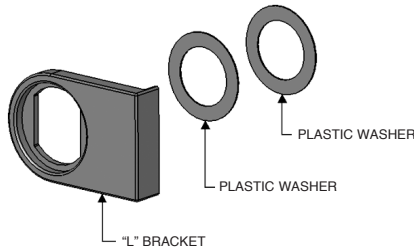

UNIVERSAL SWITCH KIT (Lock, three tab washers and nuts not included)

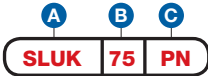

Two position maintained switch (Not Spring Loaded) Double pole double throw Toggle Switch rated 10amp/250VAC, with screw terminal.

A Package
SLUK

B Material Thickness
75 3/4"
O Other

C Plating Finish
PN Polished Nickel
SN Satin Nickel
PB Polished Brass
CF Custom Finish

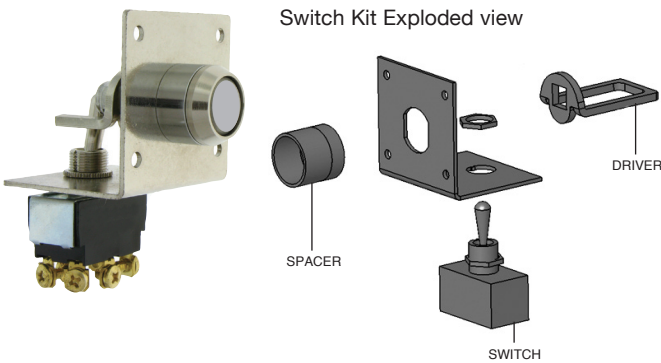

If a particular accessory is not shown in our catalog, please contact Kenstan for assistance. Kenstan may have the part as a non-catalog item or we will modify an existing part to meet your specific application. We offer prompt service in the development and quoting of custom accessory parts.

CAM TYPE

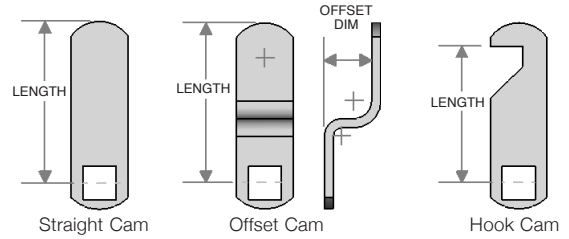

Note: All cams are reversible.

Made in the U.S.A

CAM TYPE

STRAIGHT CAM

- CAM 101** 5/8"
- CAM 102** 3/4"
- CAM 103** 7/8"
- CAM 104** 1"
- CAM 105** 1-1/8"
- CAM 106** 1-1/4"
- CAM 107** 1-3/8"
- CAM 108** 1-1/2"
- CAM 110** 1-3/4"
- CAM 112** 2"
- CAM 116** 2-1/2"

1/8" OFFSET CAM

- CAM 303** 7/8"
- CAM 306** 1-1/4"
- CAM 308** 1-1/2"
- CAM 312** 2"

1/4" OFFSET CAM

- CAM 403** 7/8"
- CAM 404** 1"
- CAM 406** 1-1/4"
- CAM 408** 1-1/2"
- CAM 410** 1-3/4"
- CAM 412** 2"
- CAM 414** 2-1/4"

3/8" OFFSET CAM

- CAM 504** 1"
- CAM 506** 1-1/4"
- CAM 508** 1-1/2"
- CAM 512** 2"

1/2" OFFSET CAM

- CAM 606** 1-1/4"
- CAM 608** 1-1/2"
- CAM 610** 1-3/4"
- CAM 612** 2"

5/8" OFFSET CAM

- CAM 712** 2"

HOOK CAM

- CAM 202** 3/4"
- CAM 204** 1"
- CAM 206** 1-1/4"
- CAM 208** 1-1/2"
- CAM 210** 1-3/4"

CUSTOM CAM

- CL CL**

Made in the U.S.A

1. Pricing: Kenstan Lock reserves the right to institute price adjustments based upon fluctuation of material costs without prior notice. Orders, or balances of orders, that have not shipped within 6 months from the original order date may be subject to a price review.

2. Payment Terms: Payment must be made at time of purchase, unless otherwise approved by Kenstan with terms of Net 30 Days from the date of the invoice. A service charge of 1.5% per month will be charged on overdue accounts.

3. Shipping: Please be sure to specify your preferred shipping method on every order. For all orders received without shipping instructions, Kenstan will use our discretion to make carrier selection based upon the most economical method of shipment available to meet your required in house date. Kenstan is not responsible for risk of loss or damage to products in transit with the selected carrier.

4. Deliveries: At Kenstan, we assemble every lock to order and strive to meet your requested in-house date. Our standard lead time is to ship within two weeks from the receipt of your order. Rush orders and emergency services are available. Unless specifically prohibited in writing by the purchaser, Kenstan reserves the right to make partial shipments of any order.

5. Inspection: Kenstan Lock inspects all products in accordance with our standard quality control procedures. Upon receipt and inspection by the purchaser, any parts proven to be defective or not as ordered may be returned to Kenstan for repair or replacement following the conditions in the "Returned Goods" section (#6) below.

6. Returned Goods: Product replacement or account credit for any returned goods will be made solely at the discretion of Kenstan and will only be accepted upon the issuance of a Return Authorization number from Kenstan's Customer Service Department. Merchandise proven to be defective, due to faulty material and/or workmanship, may be returned for full replacement or credit. Any product ordered incorrectly by the customer may be accepted for return and subject to a 50% handling charge. Locks made with special or out-of production parts are not returnable, unless prior arrangements have been made. Returned merchandise that is damaged in transit, due to inadequate return packaging, will not be accepted.

7. Warranty: Kenstan Lock warrants, for a period of one year from delivery, that our products are free from defects in material and workmanship and makes no other warranties, expressed or implied, including but not limited to the degree of security or the purchaser's application or use of our product. Kenstan Lock Co. will not warranty any locks or parts that were modified outside of our factory. In the event of a product defect, Kenstan shall only be responsible to the extent of the cost of our product, and will not accept any claims for labor or loss of merchandise.

8. Cancellation: If all or any part of an order is cancelled before the completion of the product assembly by Kenstan, the purchaser shall be responsible for payment of all assembled items as well as any special parts ordered for items remaining unassembled at the time of cancellation. If pricing on the original order was based upon Kenstan's quantity discount, a partial cancellation may affect the pricing on items already shipped and invoiced and a price adjustment will be made.

9. Catalog Dimensions and Sample Policy: Please be aware that all lock and part drawing dimensions carry a tolerance of plus or minus 1/16" and are for reference only. Please contact us for actual dimensions. All specifications are subject to change without notice. Samples products are available upon request.